

HIGH FEED TURNING



HIGH FEED TURNING



Contents

04

Why High-Feed Turning?

- Cost reduction solution through productivity improvement
- ISO turning vs. High-feed turning

06

What is High-Feed Turning?

- High-feed turning principle
- Chip thickness comparison by feed-rate
- TaeguTec high-feed turning line

08

High-Feed Turning Lines

- **WINTURN**
- **POSTURN**
- **TURN SPEED**



12

"How" Applications

- Various applications
- Examples
- Recommended program method

16

Case Studies

20

Insert Choice

- Insert selection by workpiece material

Cost reduction solution through productivity improvement

Productivity improvement by reducing machining time

In the recent manufacturing industry, reducing production costs has become a top priority for companies' profitability due to the increasing costs of raw materials and labor. One effective way to reduce production costs is to improve productivity by reducing machining time. While the tool cost represents only about 3% of the overall production cost structure for machining, reducing overhead costs through productivity improvement can be the most effective approach. With the use of TaeguTec high-feed turning products, we propose an optimal solution for improving productivity by reducing machining time.

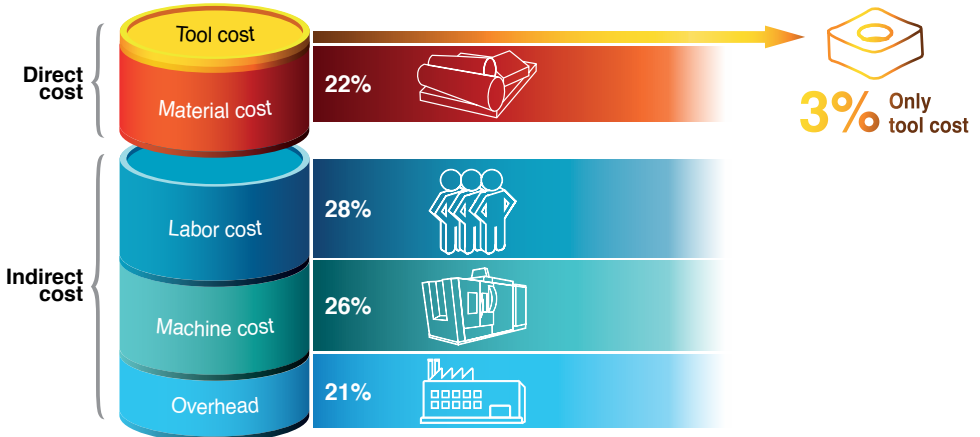

Cost structure in a typical manufacturing company

What's the best way to cut costs?

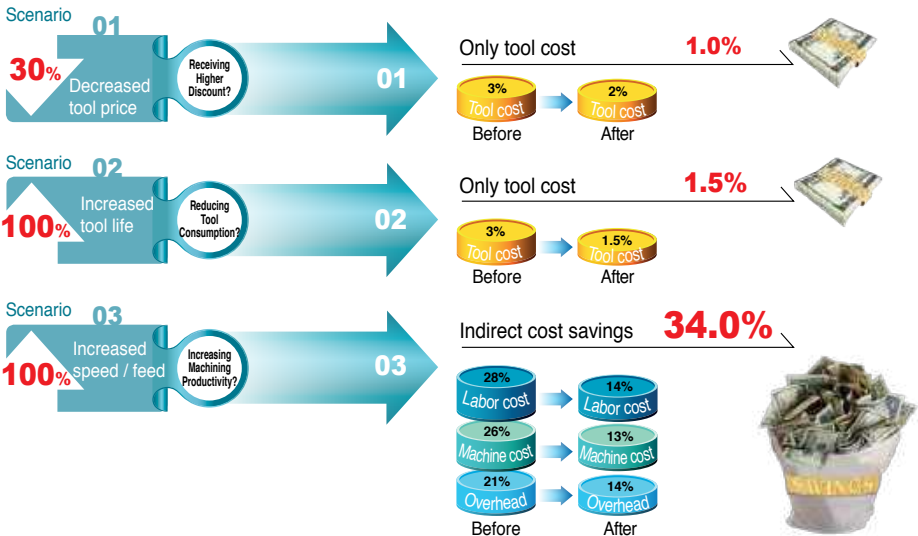

ISO turning Vs. High-feed turning

2 Times productivity



High-feed

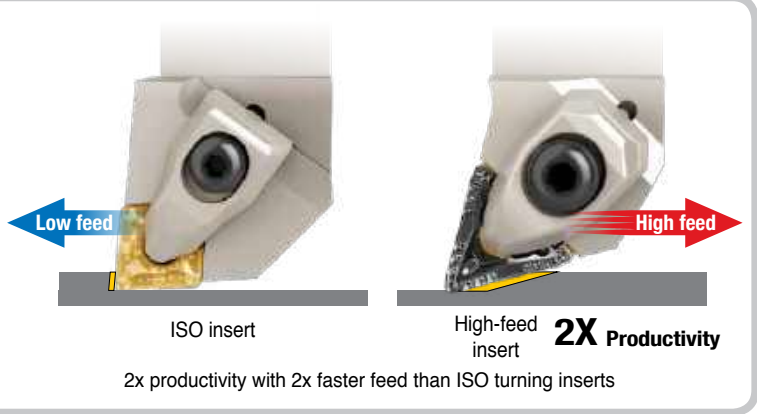

2x productivity with 2x faster feed than ISO turning inserts

2 Times tool life



Longer tool life

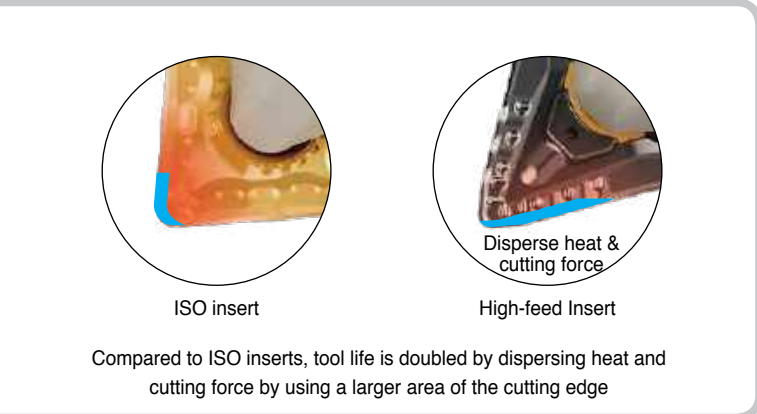

Compared to ISO inserts, tool life is doubled by dispersing heat and cutting force by using a larger area of the cutting edge

2 Rough & Finish in one tool in 1



All-directional turning

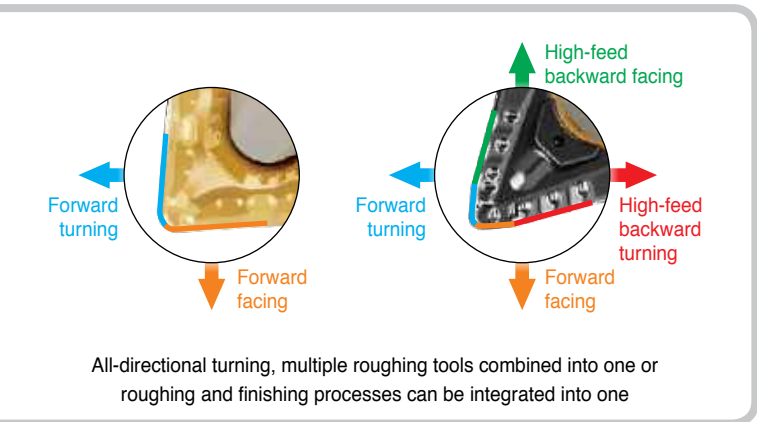

All-directional turning, multiple roughing tools combined into one or roughing and finishing processes can be integrated into one

High-feed turning principle

This insert harnesses the principle of reducing the entering angle, while keeping the same chip thickness, allows a higher feed rate.

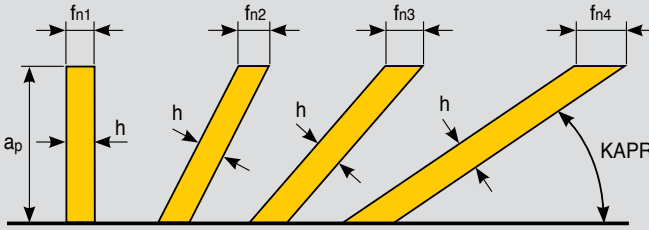

Entering angle (KAPR) and feed rate at the same chip thickness







$$* f_n = h / \sin(KAPR)$$

- f_n : Feed rate
- h : Chip thickness
- KAPR: Lead angle

$$* \text{Chip removal ratio} = f_n \times a_p \times v$$

- a_p : Depth of cut
- v : Cutting speed

TaeguTec high-feed turning line

Product lines Cutting conditions	  TNMV 21-BM		  ZNMV 14-BM	
	Processing direction			
f_n Max. (mm/rev)	1.2	0.6	1.0	0.6
a_p Max. (mm)	2.0	3.5	2.5	2.0
KAPR (°)	15	95	23	95

Chip thickness comparison by feed-rate

The figure below illustrates that a high-feed tool with a smaller entering angle requires less feed to achieve the same chip thickness as conventional ISO inserts. This can significantly increase machining efficiency and result in a drastic reduction in machining time.

CNMG

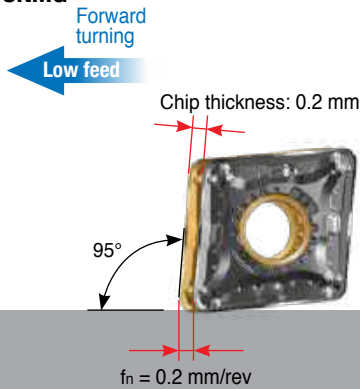

TNMV

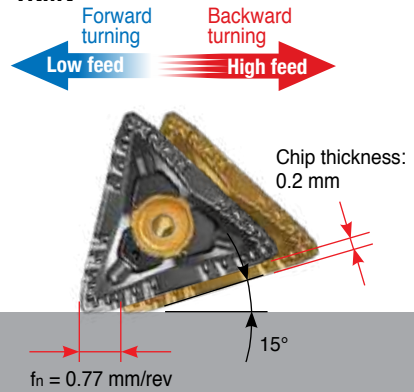

POSTURN

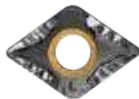

XNMV 11-BM

TURN SPEED

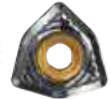

FCMX 10-HFG



0.8

0.4

3.0

1.8

3.5

2.0

16.4

93

15



Machining Video

6 Cutting edges insert for all-directional & high-feed back turning

Serrated cutting edge
Perfect chip evacuation



6 corners

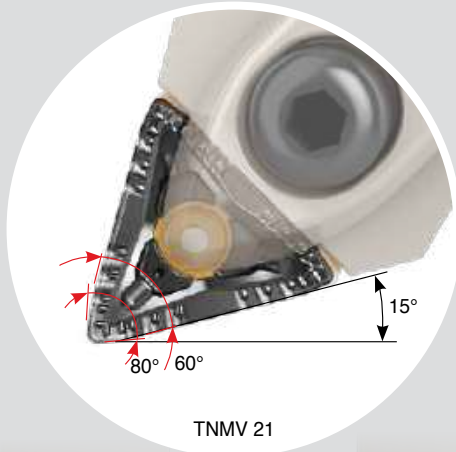

All-directional turning



High-feed backward turning
Maximize productivity



Replace
CNMG
insert

Low feed

a_p Max.
= 3.5 mm

f_n Max. = 0.6 mm/rev

High feed

a_p Max.
= 2.0 mm

f_n Max. = 1.2 mm/rev





4 Cutting edges insert for all-directional & high-feed back turning

Serrated cutting edge
Perfect chip evacuation



4 corners

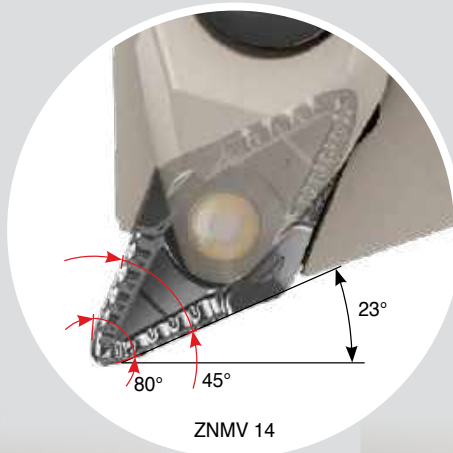

All-directional turning



High-feed backward turning
Maximize productivity





70° Corners insert for all-directional & high-feed back turning

Optimized cutting edge

Optimized cutting edges for forward and backward turning



4-corner negative

Right hand & left hand insert

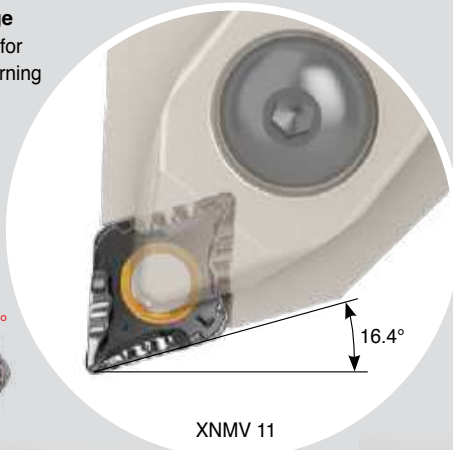
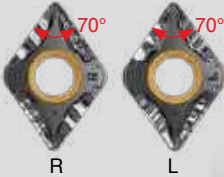

High-feed backward turning

Maximize productivity



Serrated cutting edge

Perfect chip evacuation



Low feed

a_p Max.
= 3.5 mm



f_n Max. = 0.4 mm/rev

High feed

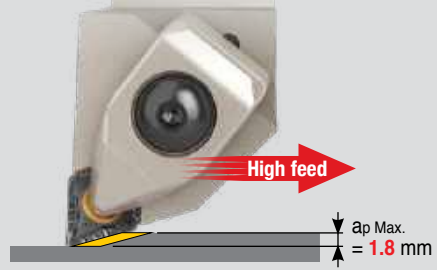

a_p Max.
= 1.8 mm

f_n Max. = 0.8 mm/rev





High-feed turning for left and right bi-directional machining

Robust and stable fastening structure

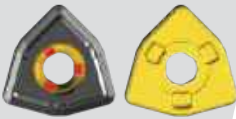

6-corner single-sided 3 index

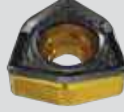

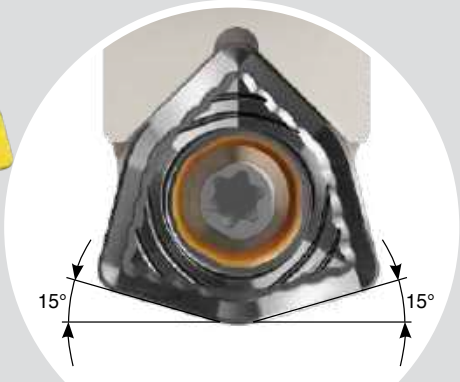

FCMX 10

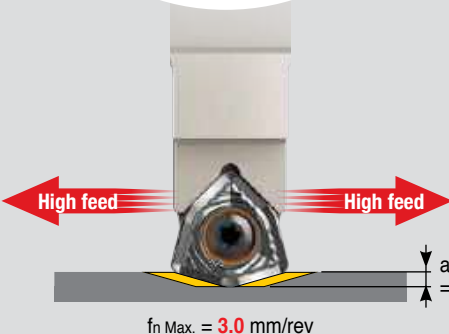

ap Max. = 2.5 mm
fn Max. = 3.0 mm/rev

Excellent chip control



High-feed backward turning
Maximize productivity



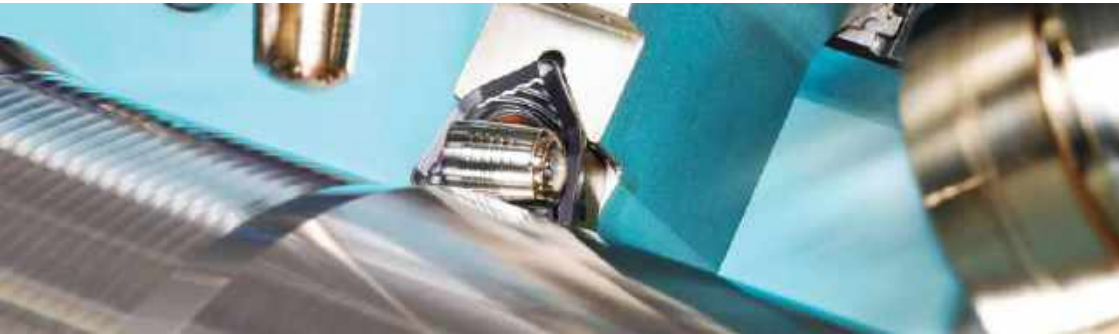

Various applications



Short parts

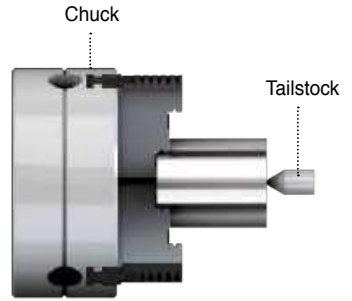

Short part + Tailstock

Examples



Bearing hub



Tripod joint



Input flange



Ball joint



Long part + Tailstock



Electric motor shaft



Sun gear shaft

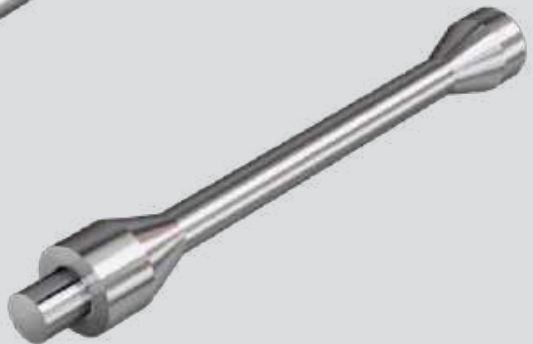

Input, output shaft

Recommended program method

Radial entry tool path

When using a circular interpolation tool path with a radius of 0.3 mm/rev feed rate, it is recommended to increase the feed rate for backward high-feed turning. It is important to note that the circular interpolation tool path radius should be equal to the depth of cut at a feed rate of 0.3 mm/rev. This is because circular interpolation helps prevent sudden load changes, insert chipping, and tool damage. Additionally, maintaining a constant cutting depth ensures better chip control during the turning process.

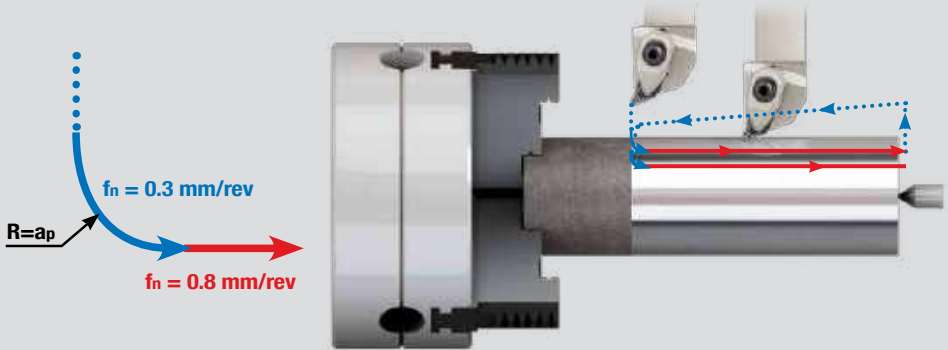

Profile machining

Lower the feed rate when the lead angle increases, higher the feed rate when the lead angle decreases
 - When machining a profile, the chip thickness and lead angle both change depending on the direction.
 If machining with the same feed, the chip thickness and the cutting load increases as the lead angle

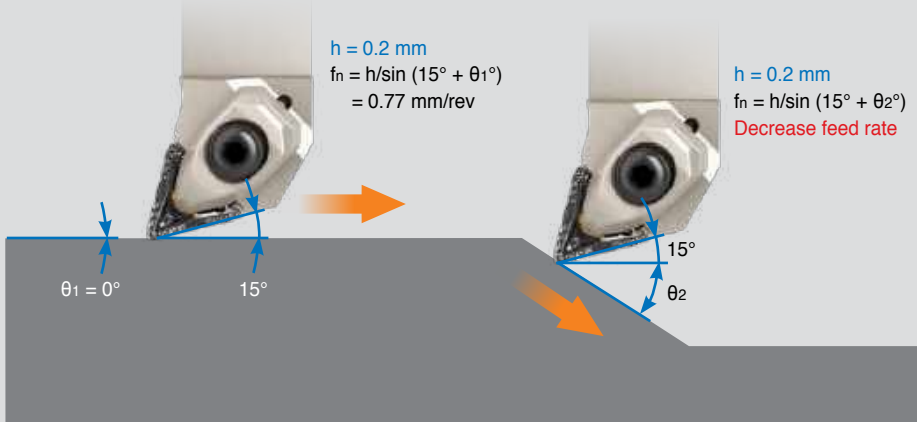

- f_n : Feed rate / a_p : Depth of cut / h : Chip thickness

Machining corner parts of forged products

3-4 passes of "Circular interpolation" + "Backward high-feed turning"

- Forged products often have additional mill scales on the corners that require extra tool passes to remove. However, traditional programming techniques may have limited chip evacuation space, resulting in the formation of long chips. To prevent poor surface roughness and machine downtime caused by long chips, backward high-feed turning is recommended as it creates sufficient chip evacuation space.

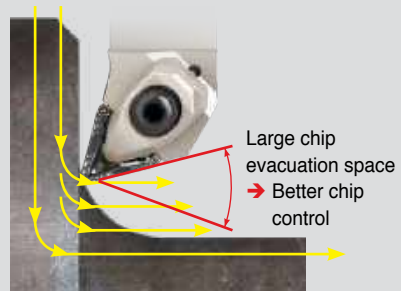
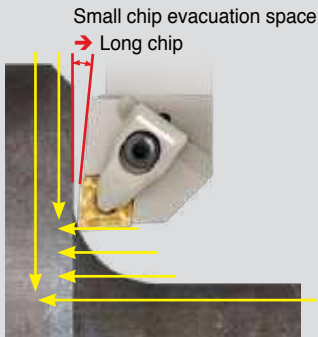
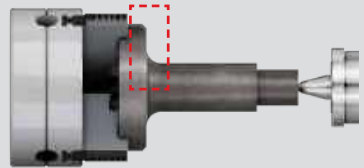

increases or the chip thickness decreases, making it difficult to control chipping as the lead angle decreases. Changing the feed to have the same chip thickness as the lead angle changes can prevent rapid cutting load changes and keep chip control constant.

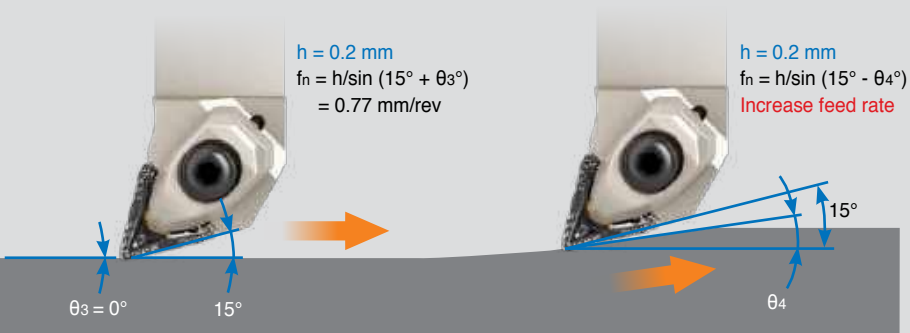

High-feed backward turning roughing

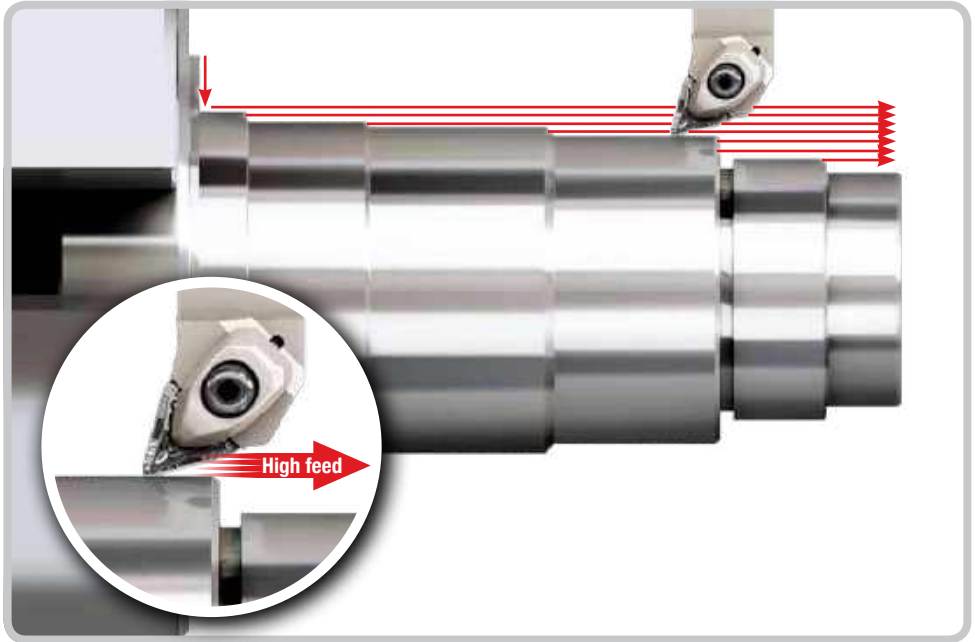

Competitor

CNMG 12

530 seconds

TaeguTec

WinTURN
TNMV 21



300 seconds

75%
Productivity
increase

Cycle time

		Competitor	TaeguTec WinTURN
Insert		CNMG 12 (ISO type)	TNMV 210908-BM TT8125B
Holder		TCLNL 3232 P12	TTQNL 2525 M2109
Speed	V (m/min)	210	210
Feed rate	f_n (mm/rev)	0.25	0.8
Depth of cut	a_p (mm)	2.0	1.5
Cycle time		530 seconds	300 seconds

High-feed backward turning roughing

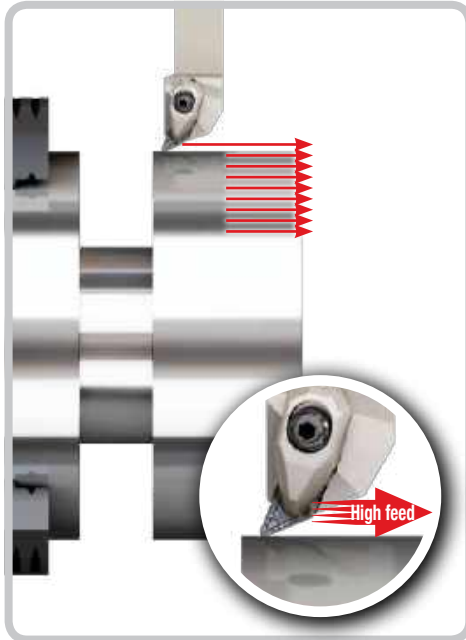

Forward turning finishing

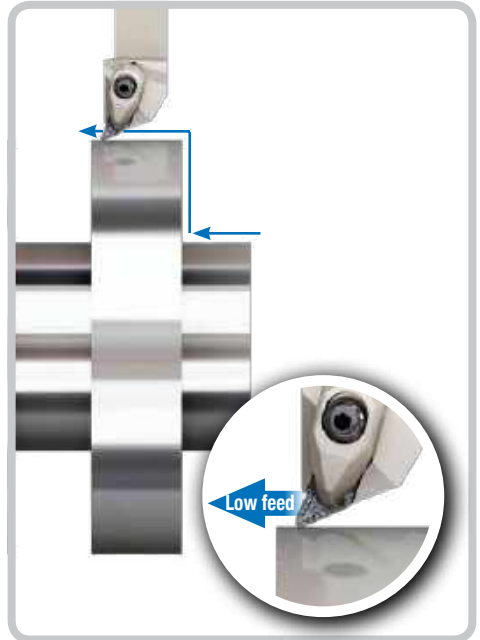

Competitor

CNMG 16

150 seconds

TaeguTec

POS TURN
ZNMV 14



100 seconds

50%
Productivity increase

Cycle time

		Competitor	TaeguTec POS TURN
Insert		CNMG 16 (ISO type)	ZNMV 141008-BS TT3020
Holder		TCLNL 2525 M16	TZQNR 2525 M1410
Speed	V (m/min)	35	35
Feed rate	f_n (mm/rev)	0.3	0.8
Depth of cut	a_p (mm)	2.5	1.5
Cycle time		150 seconds	100 seconds

High-feed backward turning roughing / forward turning finishing

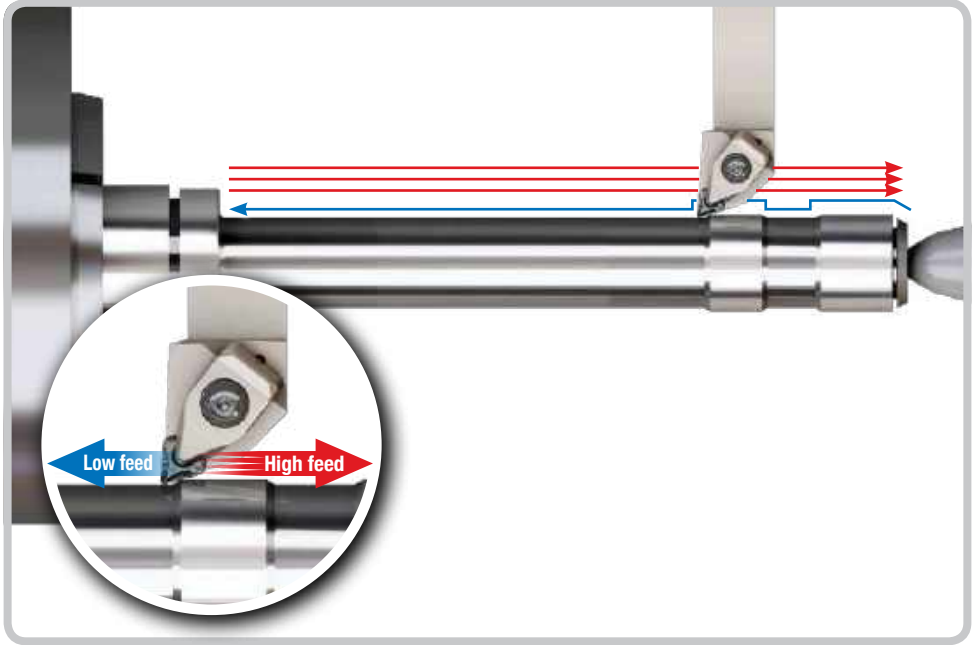

Competitor

DNMG 15

7 minutes

TaeguTec

POSTTURN
XNMV 11



5 minutes

40%
Productivity increase

Cycle time

		Competitor	TaeguTec POSTTURN
Insert		DNMG 15 (ISO type)	XNMV 110508R-BM TT8115B
Holder		TDJNR 2525 M10	TXJNR 2525 M1105
Speed	V (m/min)	150	180
Feed rate	f_n (mm/rev)	0.3	0.7
Depth of cut	a_p (mm)	0.75	0.75
Cycle time		7 minutes	5 minutes

High-feed bi-directional roughing

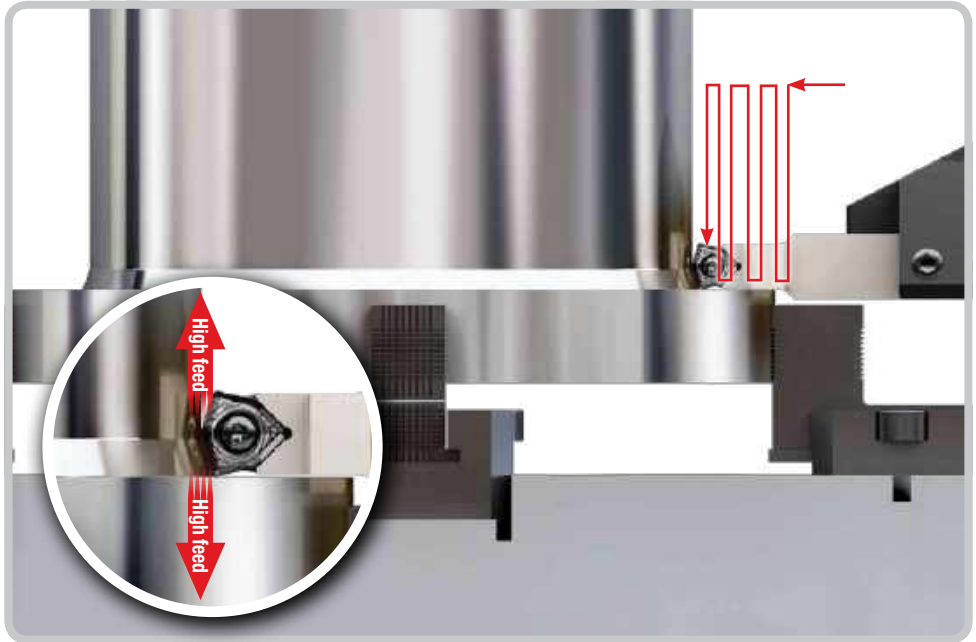

Competitor

CNMG 19

28 seconds

TaeguTec

TURN SPEED
FCMX 10



22 seconds

27%
Productivity
increase

Cycle time

		Competitor	TaeguTec TURN SPEED
Insert		CNMG 19 (ISO type)	FCMX 100616 HFG TT8125B
Holder		C6-PCLNR (Capto)	SFXCN 2525 P1006 / C6 ASHR 25-1
Speed	V (m/min)	200	200
Feed rate	f_n (mm/rev)	0.4	2.5
Depth of cut	a_p (mm)	8.0	1.5
Cycle time		28 seconds	22 seconds

Insert selection by workpiece material

ISO	WINTURN TNMV 21	POSTURN ZNMV 14	POSTURN XNMV 11	TURN SPEED FCMX 10
P	 BM 1 st TT8125B 2 nd TT8115B	 BM 1 st TT8125B 2 nd TT8115B	 BM 1 st TT8125B 2 nd TT8115B	 HFG 1 st TT8125B 2 nd TT8115B
		 Y-BF 1 st TT8125B 2 nd TT8115B		
M	 BS 1 st TT9225 2 nd TT9080			 HFP TT9225
S		 BS 1 st TT3020 2 nd TT3010	 BS 1 st TT3020 2 nd TT3010	

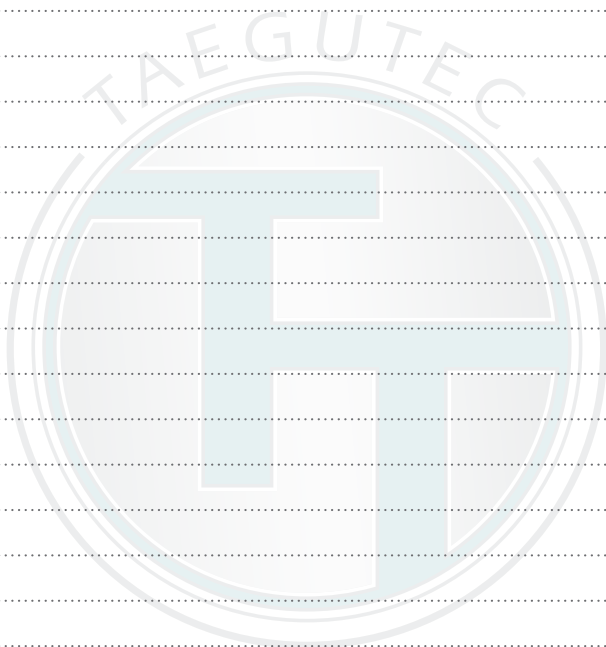

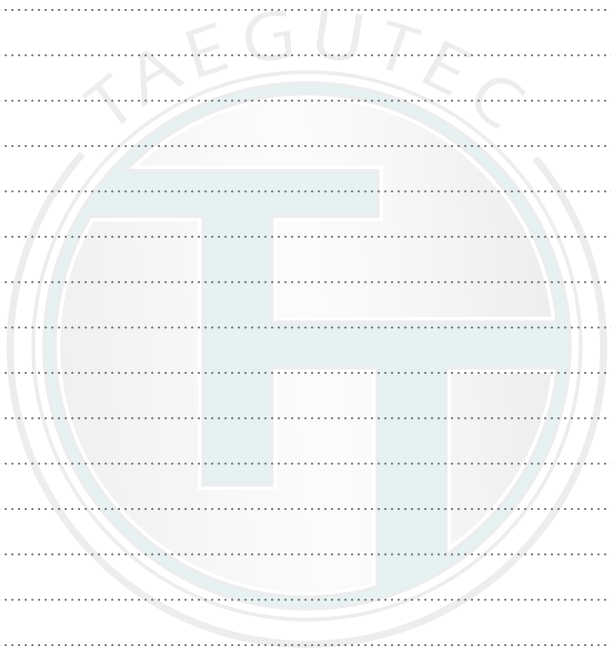

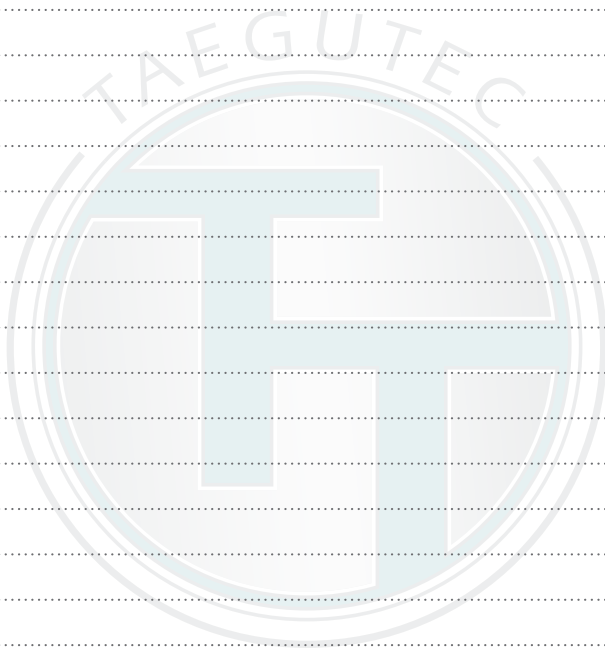



Pool CutZZ

Your Knowledge Machining Link!



Scan me!



ANDROID APP ON
Google play

Scan me!



Download on the
App Store